



**IMMERSIV
TECHSPHERE**

we automate efforts...

ENGINEERING EXCELLENCE IN CONTAINMENT & PROCESS SOLUTIONS

Customized Design, Analysis & Automation Services

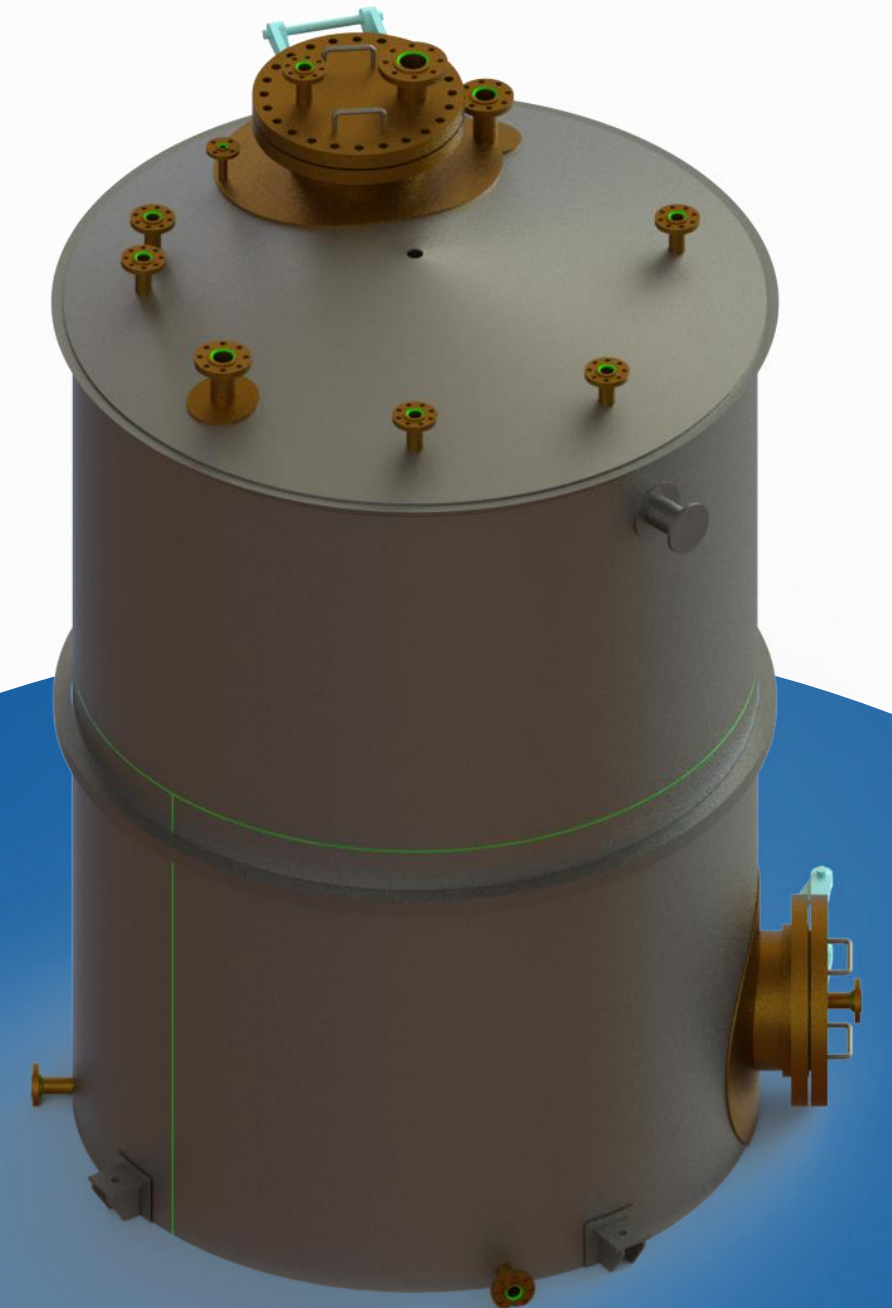



About Us

- We are a team of experienced mechanical design engineers supporting the Manufacturing, Process, Oil & Gas, Pharmaceutical, Chemical and many more industries with reliable engineering solutions.
- Our expertise includes **SolidWorks, Inventor, AutoCAD, FEA tools** and **automation platforms**, enabling us to deliver error free designs, efficient manufacturing drawings and validated engineering outcomes.
- We **design and develop** custom welding, machining and **assembly fixtures**, engineered for accuracy, repeatability, operator safety and ease of use, delivering faster setups, reduced downtime and higher overall efficiency.
- We also specialize in creating **industrial animations** and **EHS animations** that help clients visualize equipment, assembly, processes and safety procedures with clarity.
- With a strong commitment to ISO and ASME standards, we provide complete support from design through simulation, automation and documentation.



Precision Engineering through Drafting & Fabrication Drawings

- 2D & 3D CAD deliverables: assemblies, exploded views, sections
- Fabrication-ready docs: sheet-metal flat patterns, weld details, BOMs
- Standards: ASME Y14.5 (GD&T), ISO 2768, fabrication tolerances
- Clear interface drawings for mechanical, piping, and electrical integration

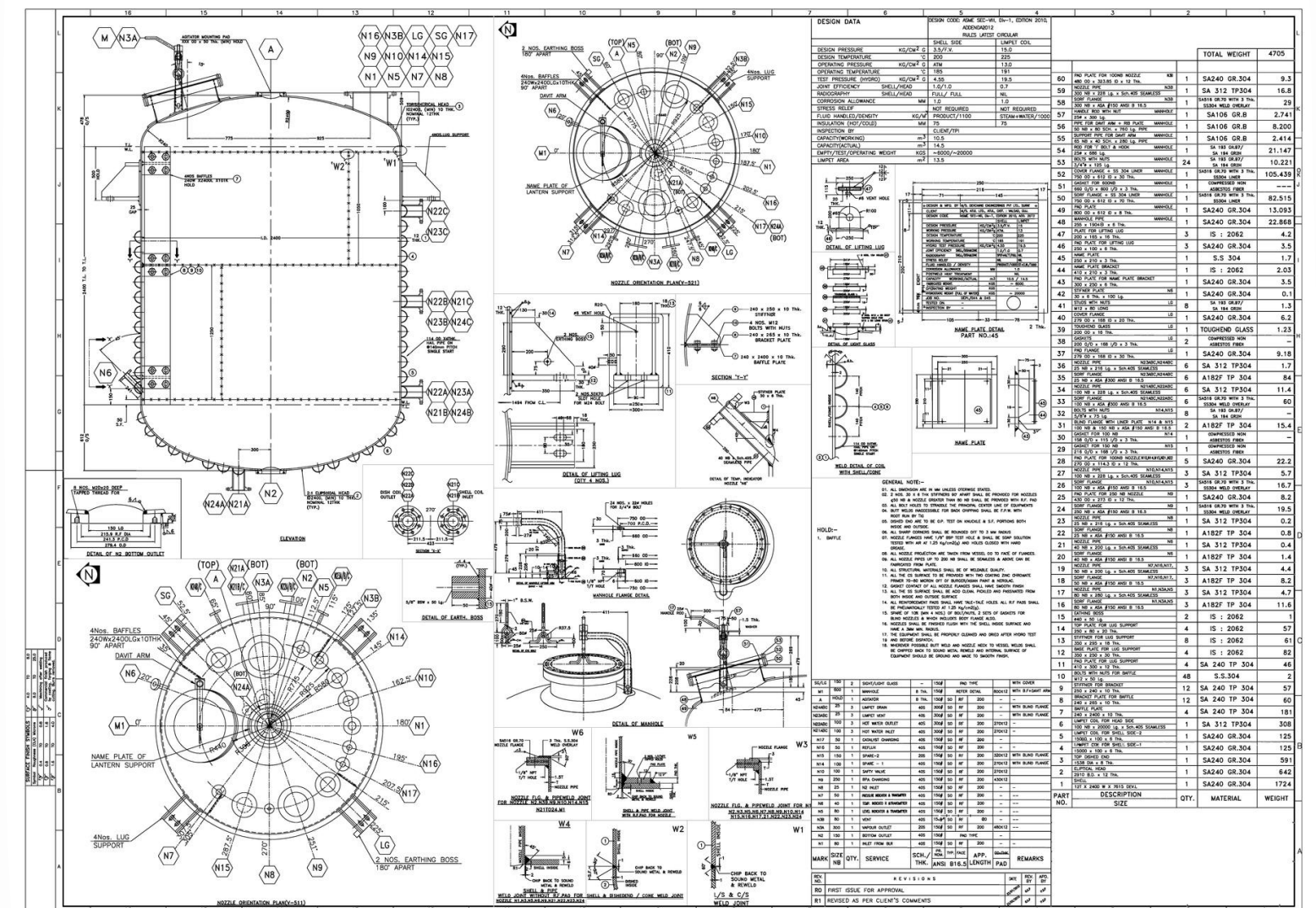



Fixtures Designing: Enhancing Accuracy and Productivity

- Specialized in designing custom fixtures.
- Expertise in welding, machining and assembly fixtures that ensure precision and repeatability.
- Designs focused on operator safety, ergonomics and productivity.
- Optimized fixture solutions that reduce setup time and improve process efficiency.
- Detailed 3D models and fabrication drawings developed using SolidWorks for seamless manufacturing.

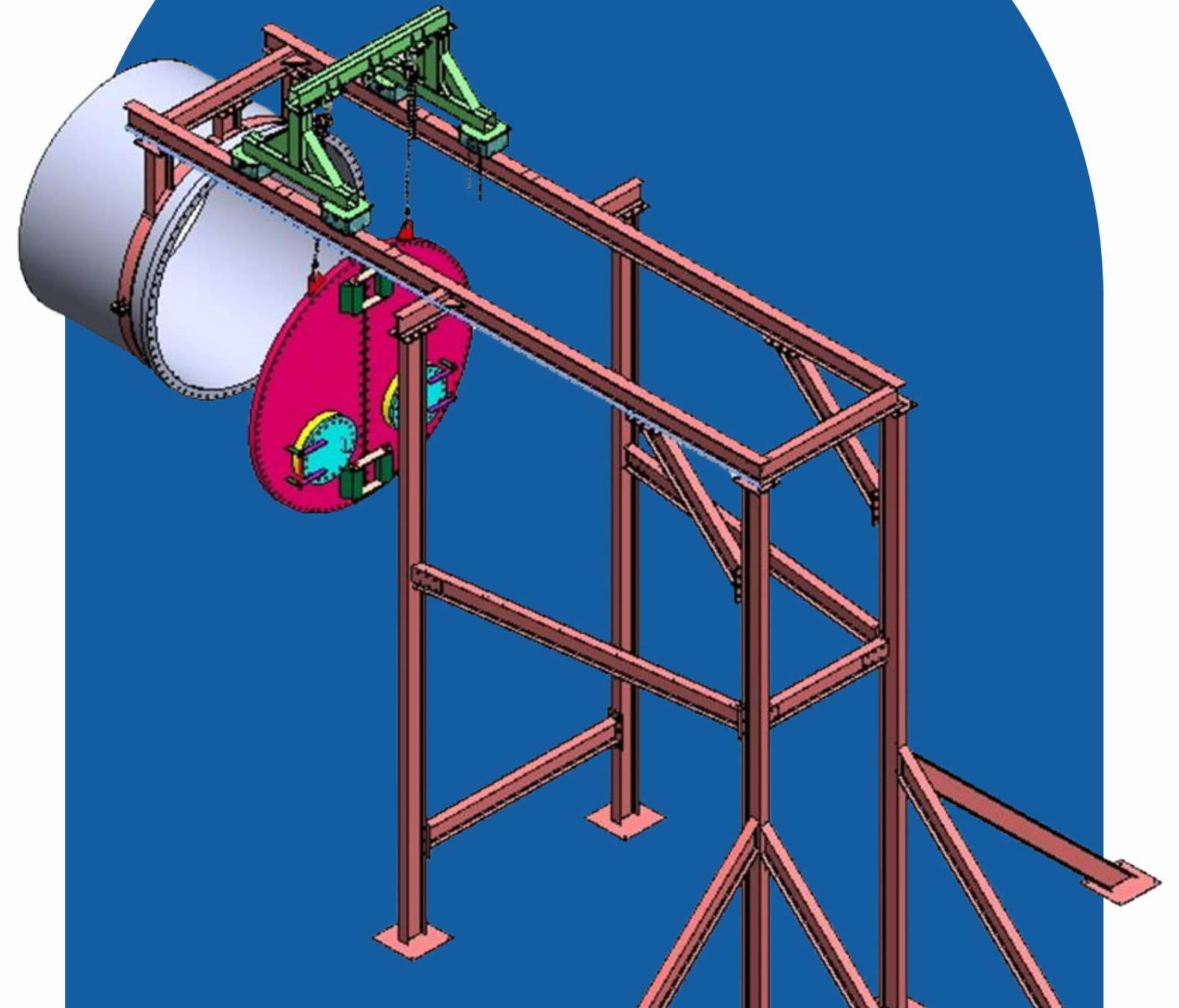

FEA Services : Ensuring Structural Integrity and Compliance



- Structural checks for isolator frames, support structures, and skids
- Static, dynamic, fatigue & buckling simulations
- Structural, Thermal & Pressure analysis
- Compliance: safety margins $>1.5-2\times$

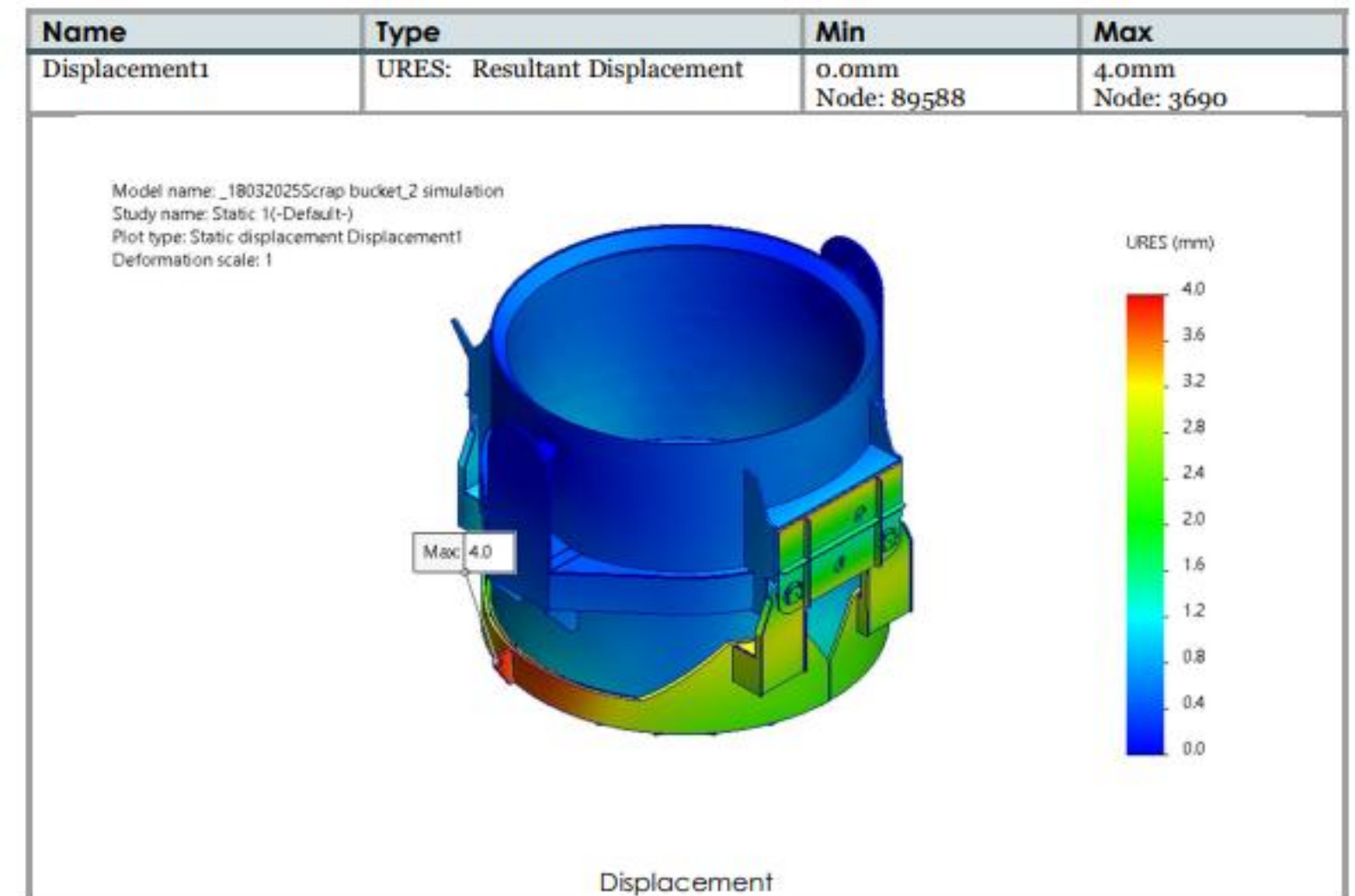



CAD Automation Services: Accelerating Design Efficiency

- Specialized in Excel, SolidWorks & Inventor API for automation
- Development of macros and add-ins to reduce repetitive tasks
- Automated creation of part, assembly and drawing files based on design rules
- Excel VBA integration for BOM, reports and data-driven modeling
- Proven to save time, minimize errors and standardize outputs for manufacturing

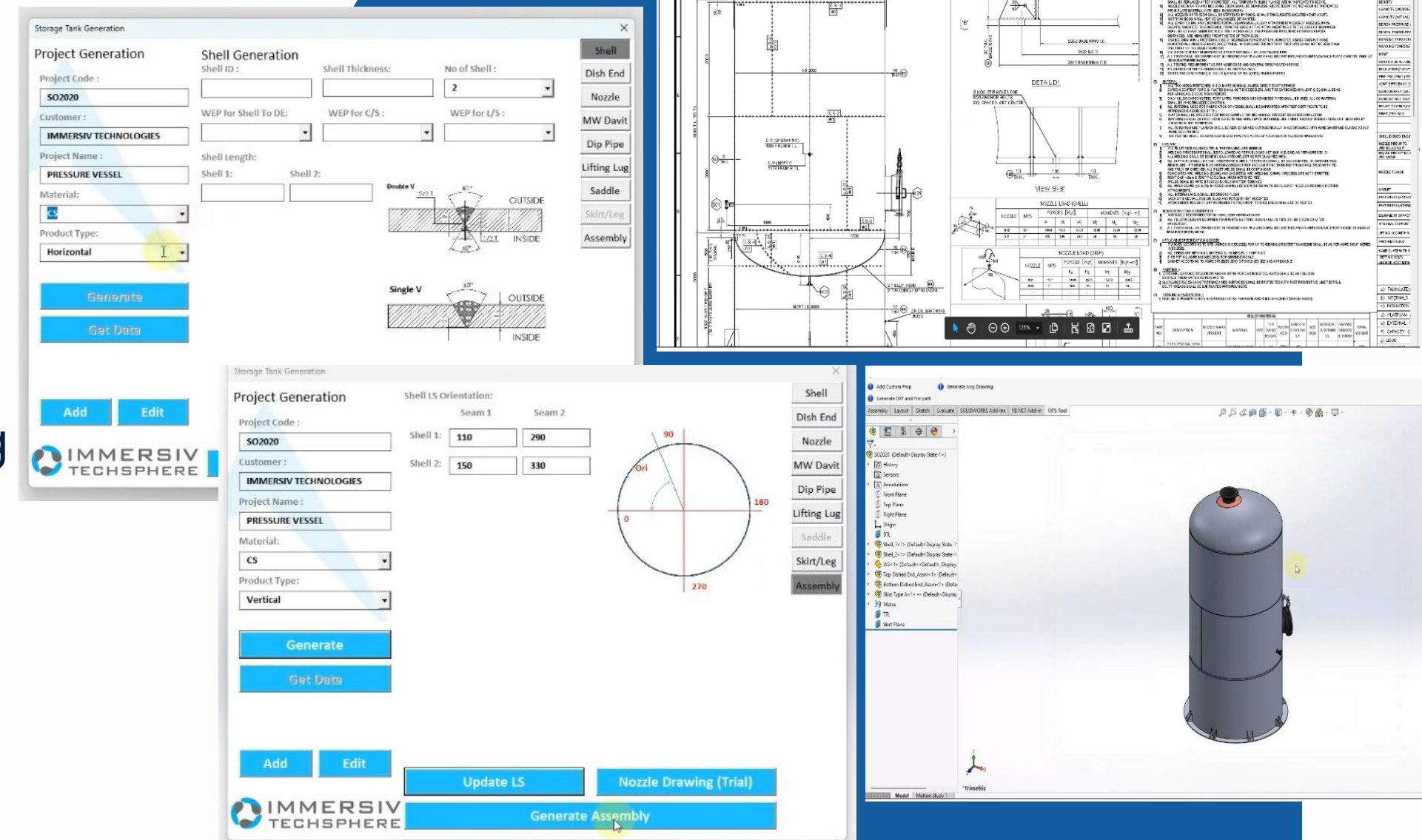

Work Samples

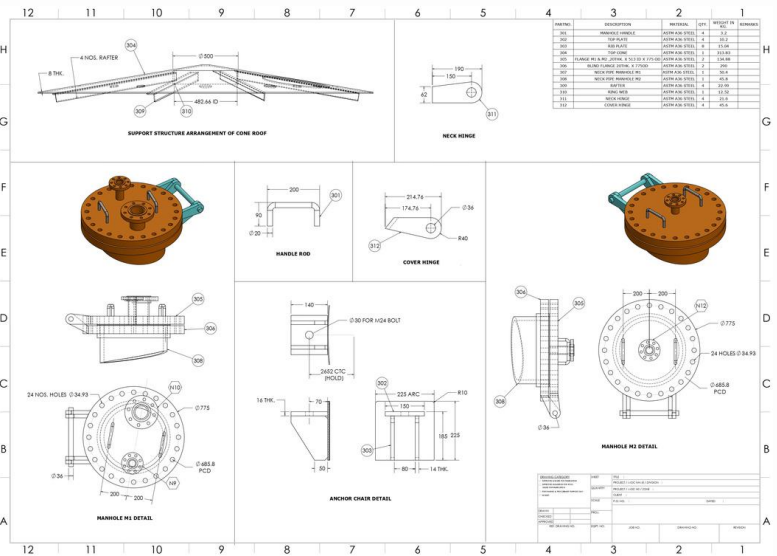
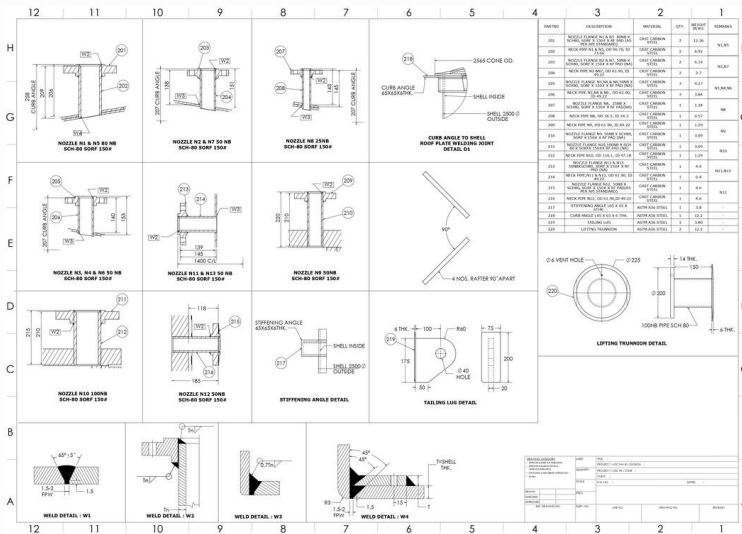
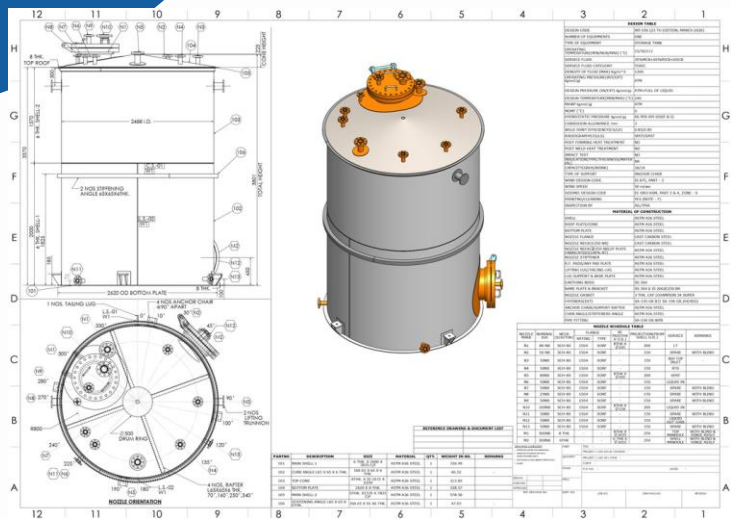

Pressure Vessel Drawings

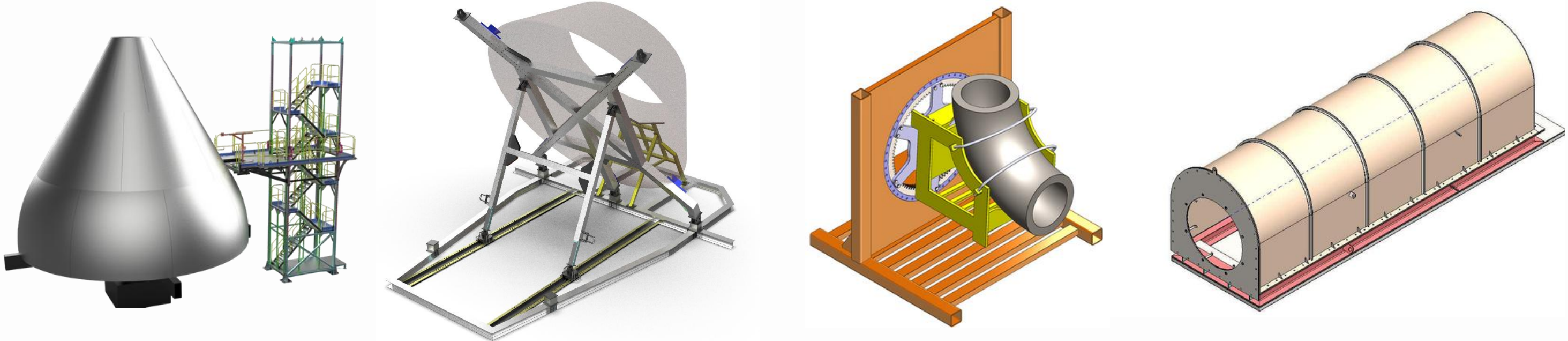

Fixtures Design

Process Visualization

- [Heat Exchanger Assembly Process](#)
 - [Skid Assembly](#)
 - [Valve Sequence and Flow](#)
- [Sheet Metal Cabinet Assembly](#)

- [Pressure Vessel CAD Automation](#)
- [Droplet Separator CAD Automation](#)
- [Staircase model & drawing Automation](#)
- [Kitchen Cabinet Assembly & drawing Automation](#)

Design Automation



Portfolio Drive Link



CLIENTELE

array

MAXXIT



INTERNATIONAL



DOMESTIC

THANK YOU!



+91 84602 55923



www.immersivtech.com



B-418,419 Monarch, Gauvrav Path
Road, Surat, Gujarat.