

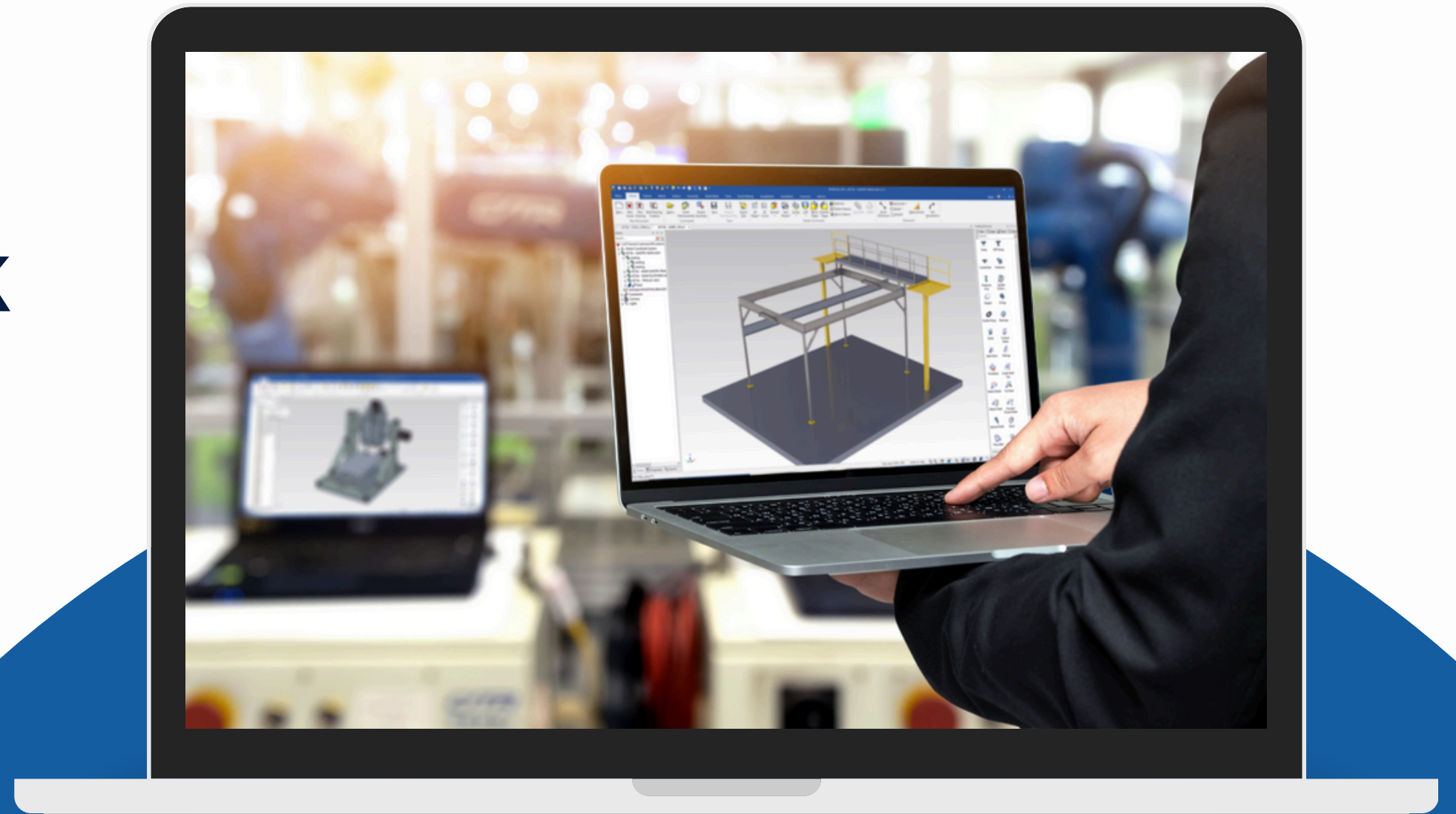

Wood Work & Wood and Metal work Furniture Design Services

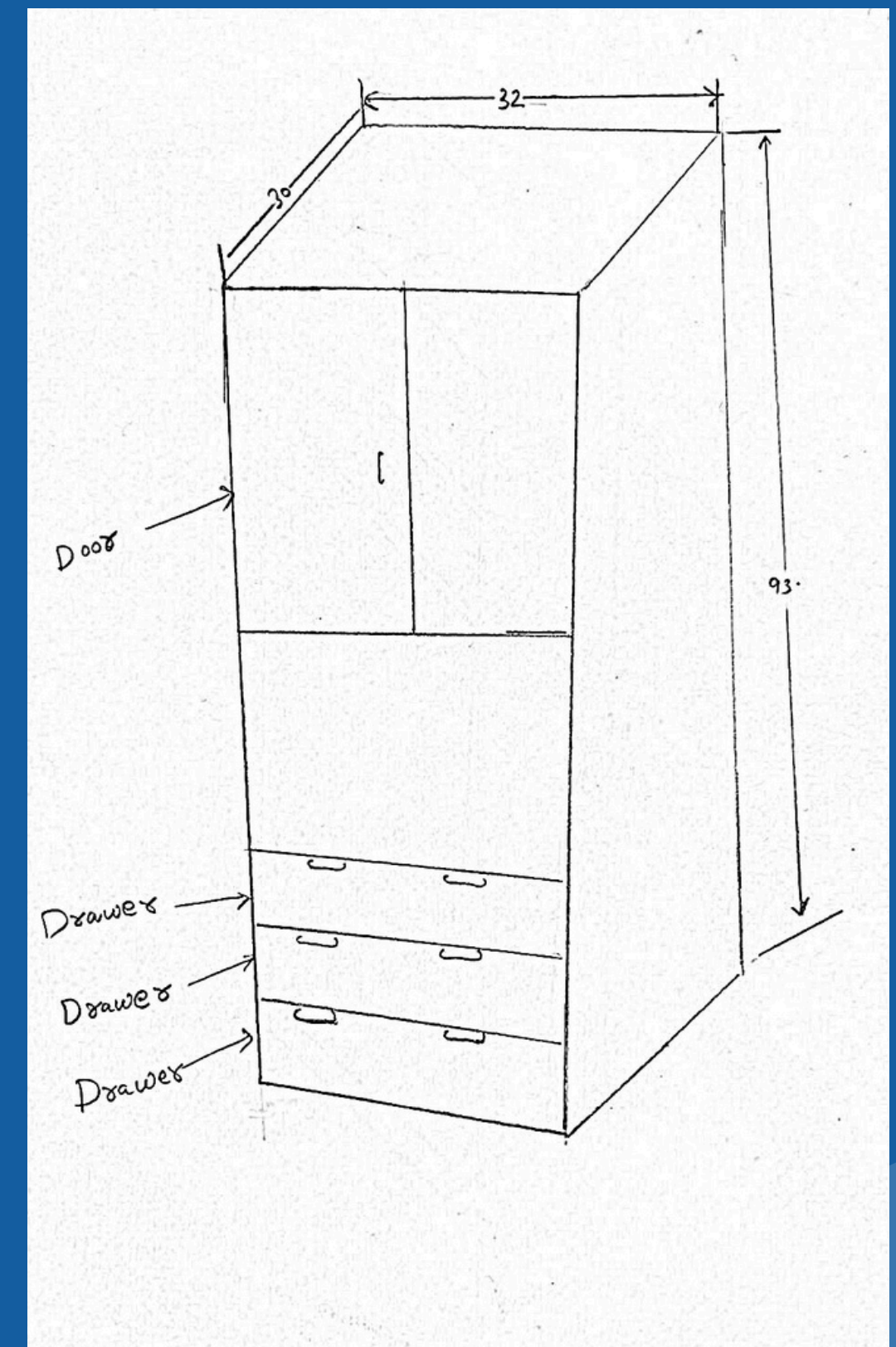

What we get from our Clients?

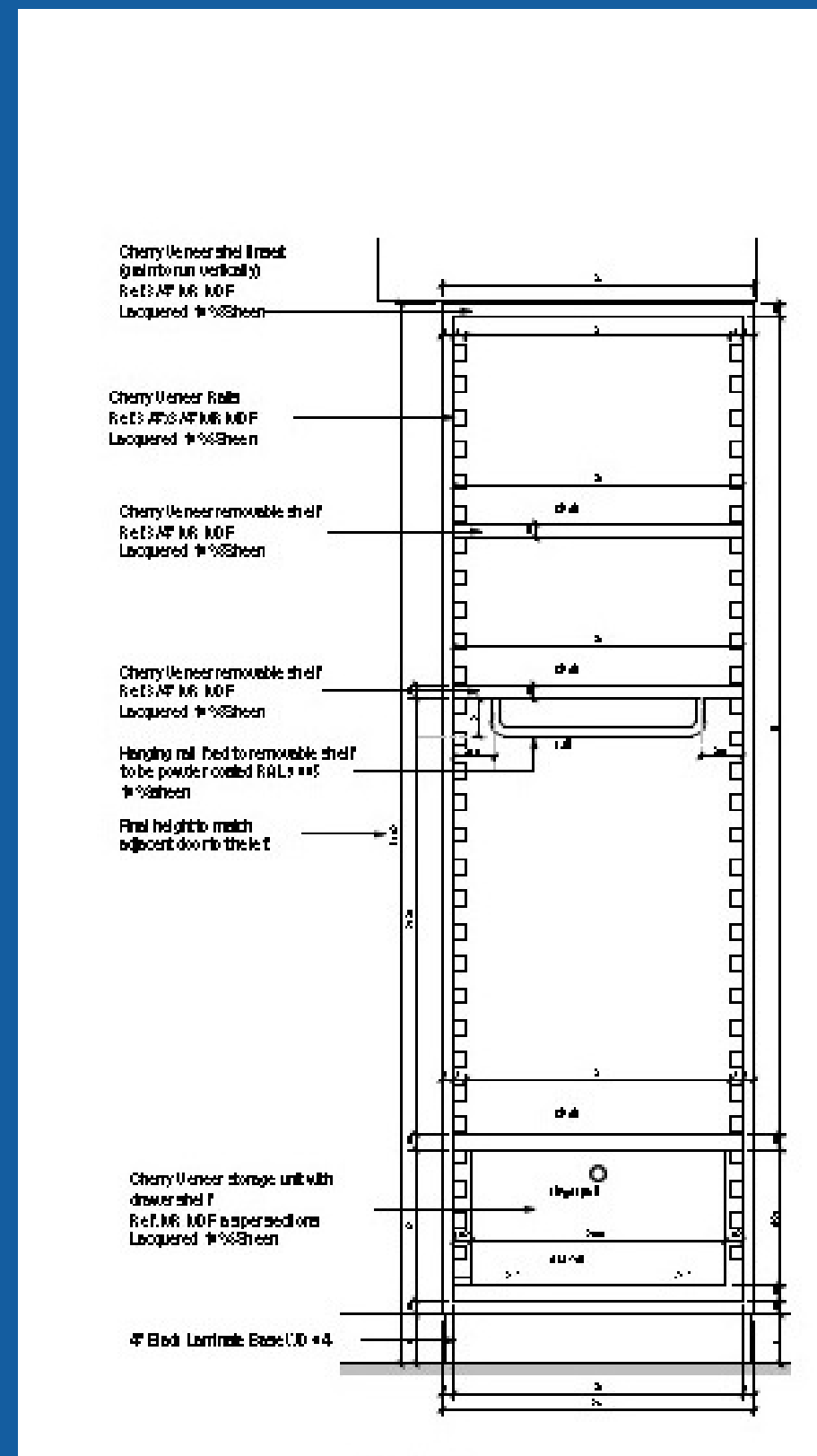
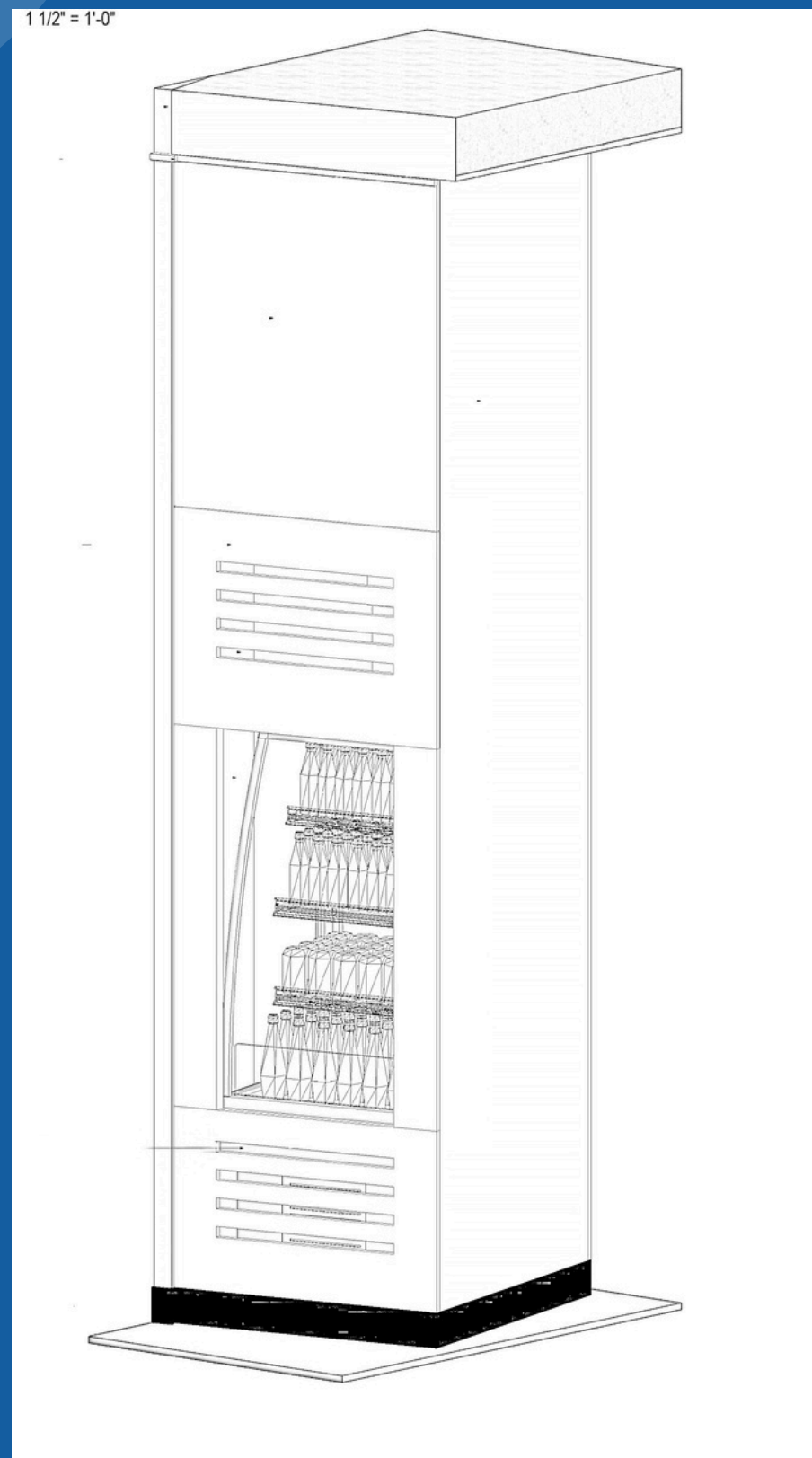

Drawings of Cabinet with Wood Work

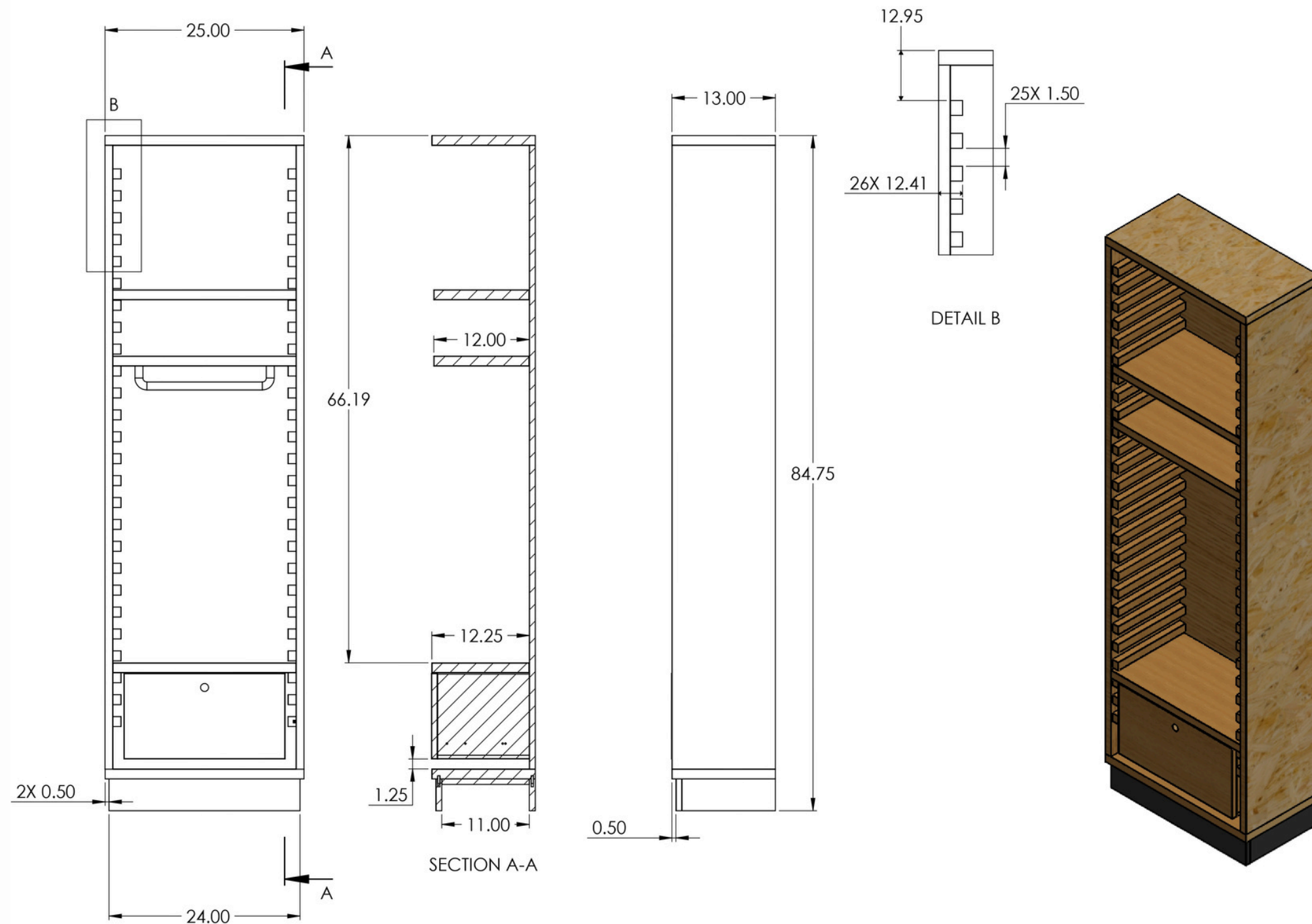

ITEM NO.	PART NUMBER	QTY.
1	97195A139_Wood Dowel Pins.step	104
2	97195A142	50
3	FIX SHELF	1
4	J-002 BACK PANEL	1
5	J-002 BOTTOM	1
6	J-002 Condiment Trash Station Toe Kick	1
7	J-002 DRAWER AND BOX ASSEM	1
8	J-002 SIDE RACKS	52
9	J-002 TOP PANEL	1
10	LEFT SIDE PANEL	1
11	REMOVABLE SHELF	2
12	RIGHT SIDE PANEL	1
13	WIRE PULL	1

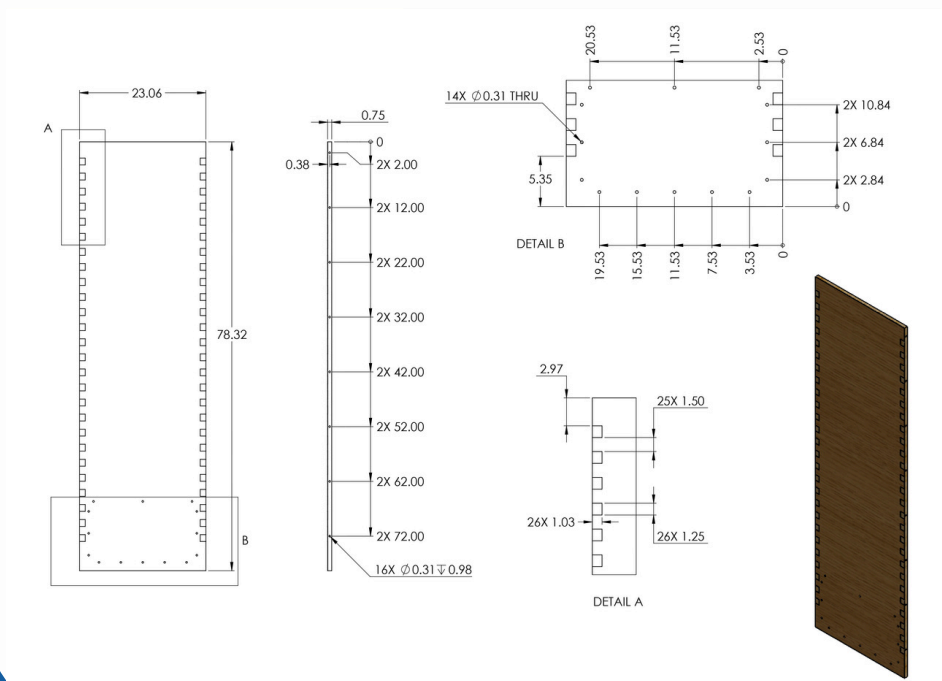
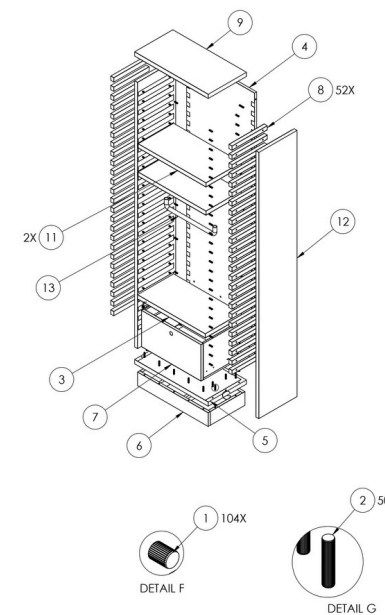
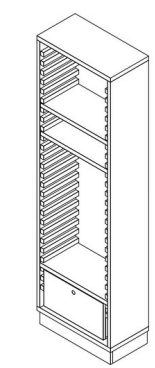

Drawings of Cabinet with Wood Work

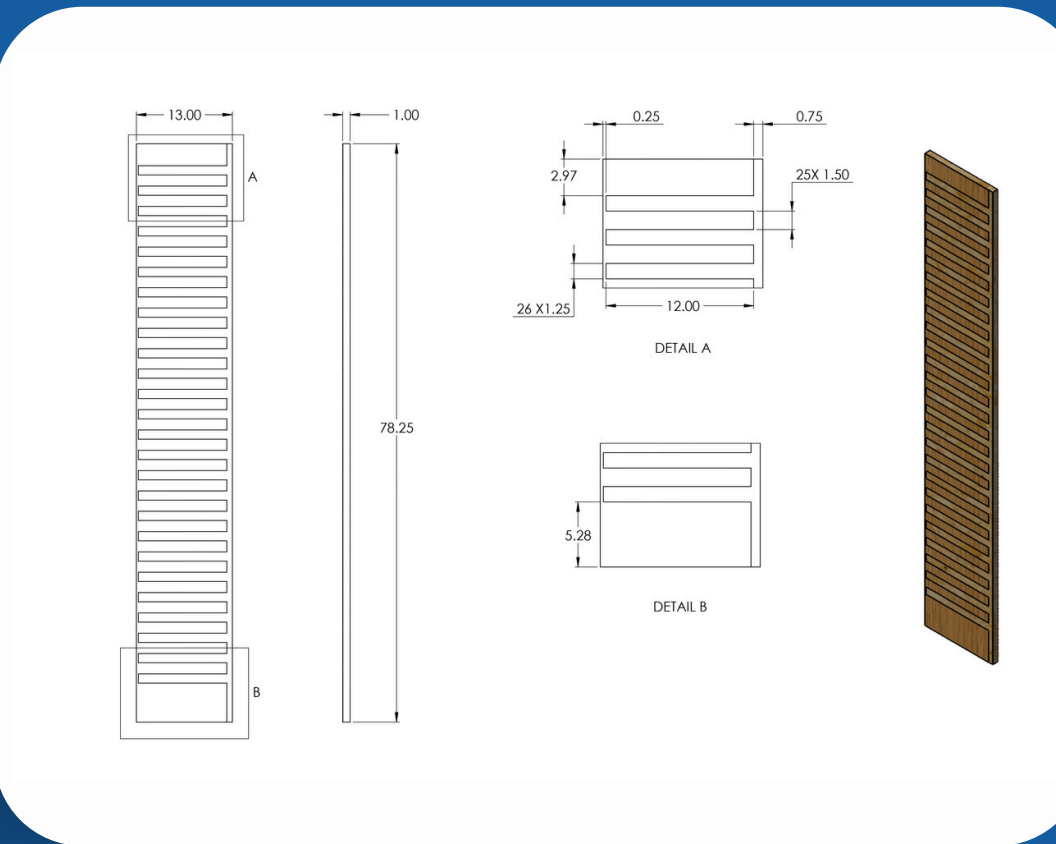
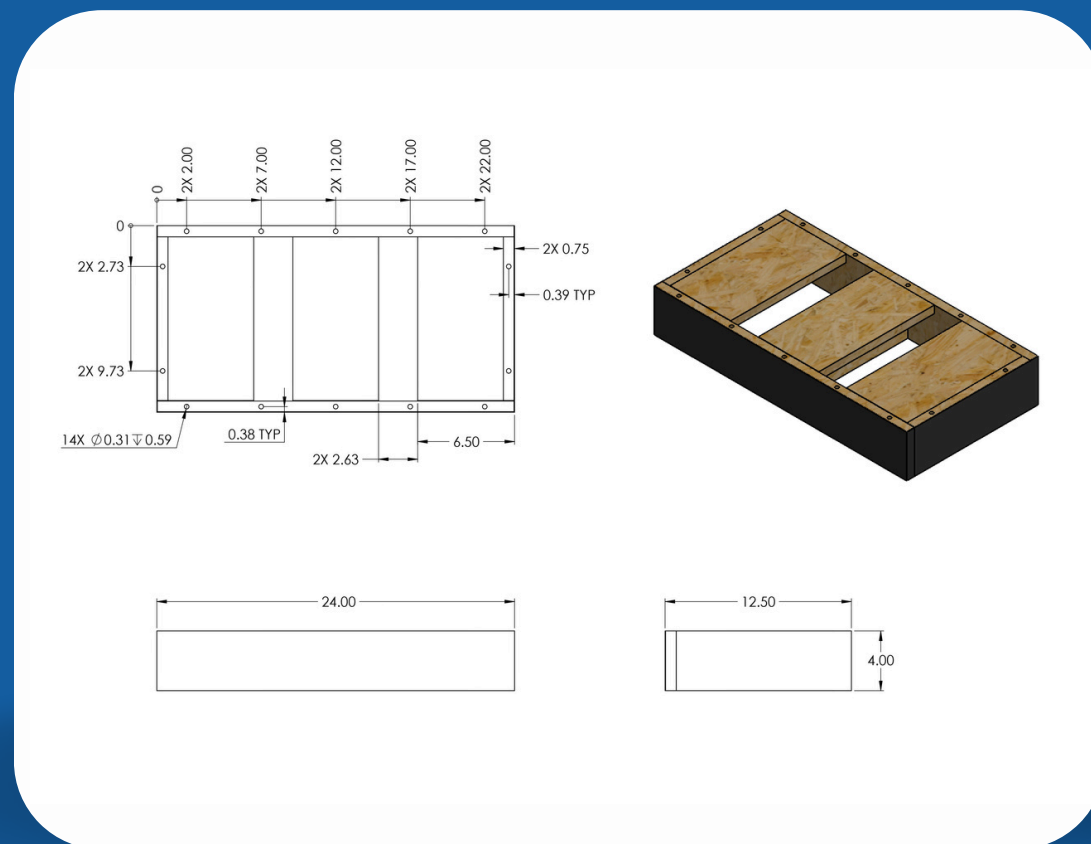
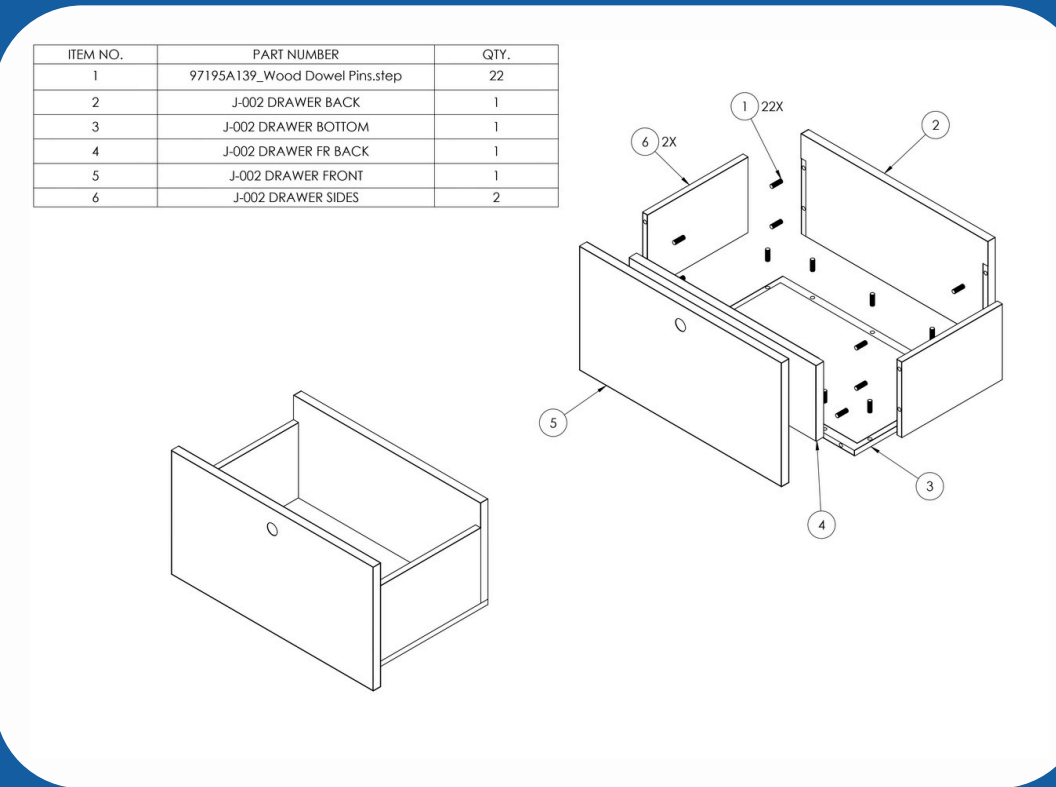
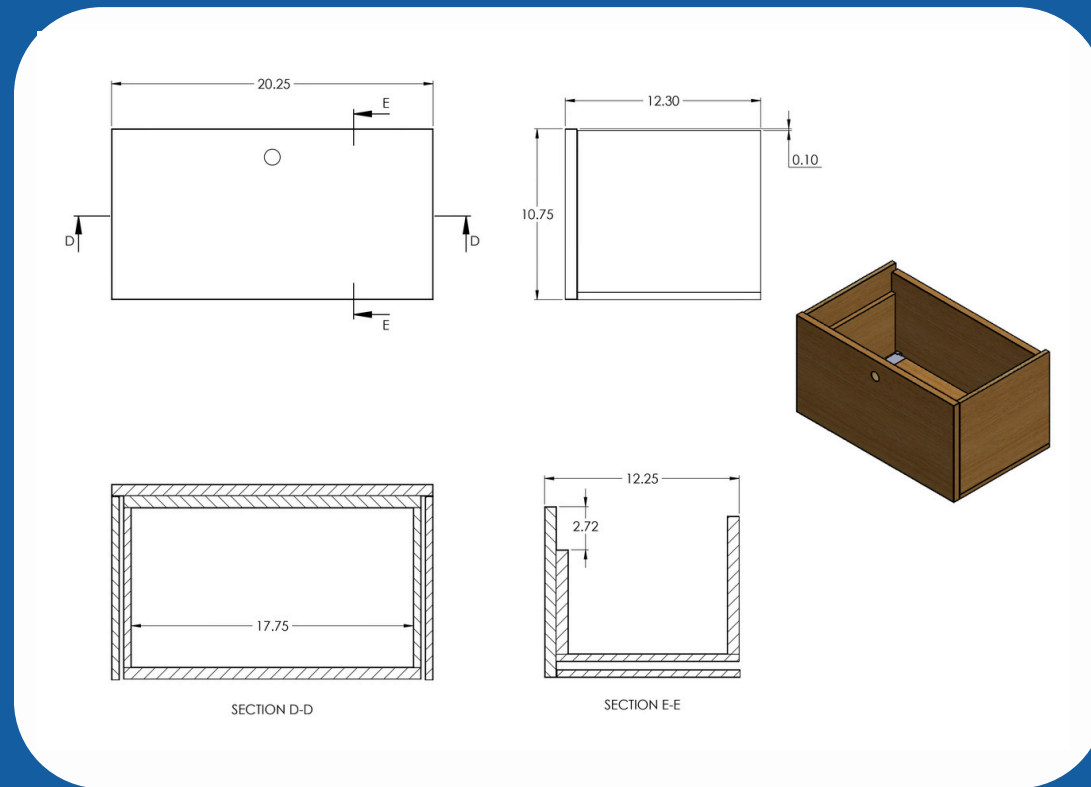







Industries we serve

- Residential
- Hospitality
- Corporate Offices

Types of Furniture

- Kitchen Cabinets
- Table & Chairs
- Wardrobe
- Bed Frame
- TV Cabinet
- Work-Station
- Book Shelves
- Filling Cabinets
- Storage cabinets

Feel free to inform us if you have any other custom requirements.

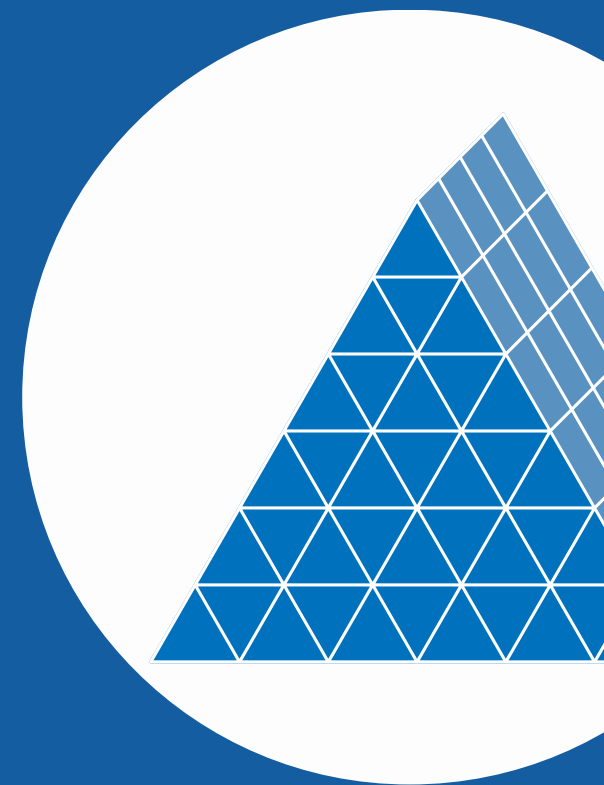



Sample of Documents which we provide:

- Drawing PDF
- DXF Files
- Step Files
- Production BOM
- Production Packet
- SolidWorks Drawing
- SolidWorks Models

Name	Date modified	Type	Size
50087-HINGE CHANNEL	21-07-2023 17:32	SOLIDWORKS Part Document	249 KB
50087-TALL BACK CROSS BRACE FRONT	21-07-2023 17:32	SOLIDWORKS Part Document	304 KB
50087-TALL BACK CROSS BRACE REAR	21-07-2023 17:32	SOLIDWORKS Part Document	384 KB
50087-TALL BACK	21-07-2023 17:32	SOLIDWORKS Part Document	1,989 KB
50087-TALL CAB WELDMENT	04-07-2023 00:59	SOLIDWORKS Assembly Document	1,540 KB
50087-TALL DOOR ASSEMBLY	04-07-2023 15:25	SOLIDWORKS Assembly Document	1,240 KB
50087-TALL INNER DOOR	21-07-2023 17:32	SOLIDWORKS Part Document	400 KB
50087-TALL INNER MINI LEFT	21-07-2023 17:32	SOLIDWORKS Part Document	993 KB
50087-TALL INNER MINI RIGHT	21-07-2023 17:32	SOLIDWORKS Part Document	1,004 KB
50087-TALL LEFT SIDE PANEL	21-07-2023 17:33	SOLIDWORKS Part Document	599 KB
50087-TALL OUTER DOOR	21-07-2023 17:33	SOLIDWORKS Part Document	389 KB
50087-TALL RIGHT SIDE PANEL	21-07-2023 17:33	SOLIDWORKS Part Document	1,138 KB
50087-TALL SOLID DOOR	04-07-2023 10:59	SOLIDWORKS Assembly Document	2,650 KB
console	30-06-2023 11:03	Text Document	17 KB
CU-50087-HC-73_A-1	21-07-2023 17:32	DXF File	26 KB
CU-50087-TB-36_A-1	21-07-2023 17:32	DXF File	143 KB
CU-50087-TBCBF-36_A-1	21-07-2023 17:32	DXF File	33 KB
CU-50087-TBCBR-36_A-1	21-07-2023 17:32	DXF File	38 KB
CU-50087-TIDW-7318D_A-1	21-07-2023 17:32	DXF File	33 KB
CU-50087-TIDW-7318DX	28-06-2023 11:41	DXF File	31 KB
CU-50087-TIDW-7318DX_A-1	21-07-2023 17:32	DXF File	32 KB
CU-50087-TIDW-7718D_A-1	28-06-2023 15:08	DXF File	33 KB
CU-50087-TIML-77_A-1	21-07-2023 17:32	DXF File	78 KB
CU-50087-TIMR-77_A-1	21-07-2023 17:32	DXF File	76 KB

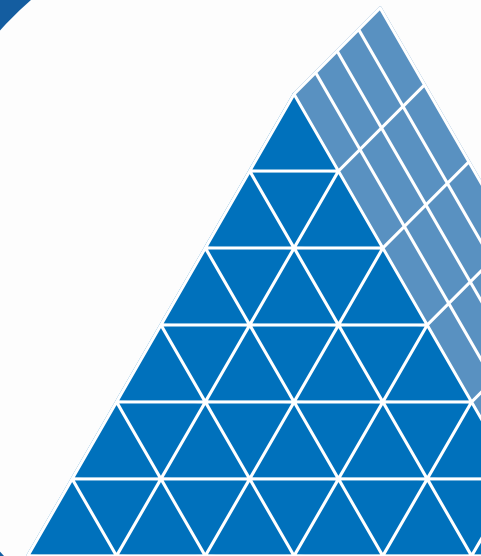

Benefits of Opting Our Design Services

- Our expert design engineers will handle the technical drawings and designing work while you can focus on production and manufacturing.
- We will provide a cost-effective solution, allowing you to save on training time, salary expense, and overhead costs.
- We offer automation of standard design procedure for creating precise technical drawings with accurate measurements and alignments to minimize manufacturing errors and ensure timely delivery for faster turnaround.
- Additionally, we can provide you with realistic 3D renders of your furniture products, which you can utilize to create a visually appealing pitch for your clients.

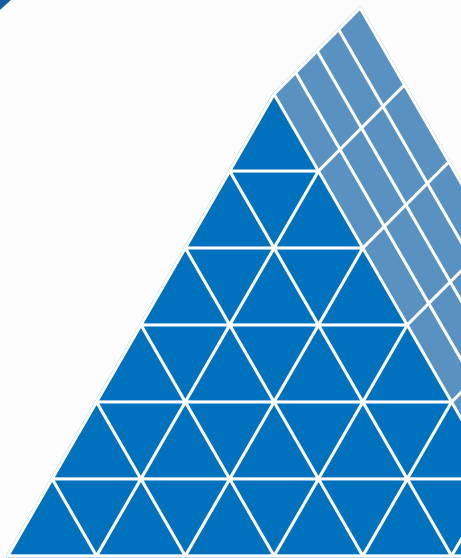



THANK YOU!



 contact@immersivtech.com

